

TEMPERATURE CONTROL SYSTEMS

Direct Operated (25mm Linear)

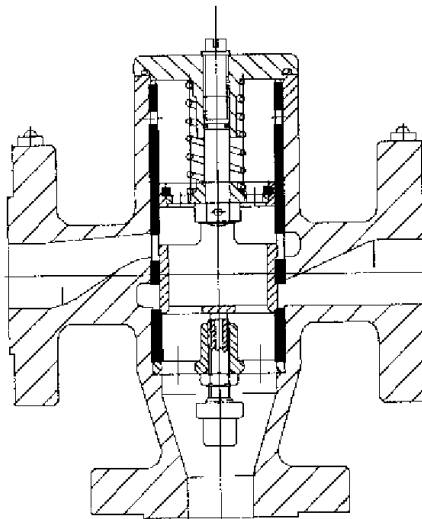

WALTON ENGINEERING CO. LTD.

61 London Road • St Albans • Hertfordshire • AL1 1LJ • England

Telephone +44 (0)1727 855616 • • Fax +44 (0)1727 841145

E-mail: sales@waltonengineering.co.uk • • Web: www.waltonengineering.co.uk

The following Walton Instruction Manuals are available:

Direct Operated (Rotary)	MANUAL\DIRECT01
Direct Operated (25mm Linear)	MANUAL\DIRECT02
Direct Operated (Twin)	MANUAL\DIRECT03
Direct Operated (Rotary) Fail - Safe	MANUAL\DIRECT04
Direct Operated (15-25mm Linear)	MANUAL\DIRECT05
Pneumatically Operated	MANUAL\PNEU01
Electrically Operated (Series 500 Actuator)	MANUAL\ELEC01
Electrically Operated (Series 3000 Actuator)	MANUAL\ELEC02
Electrically Operated (Special Integral Function)	MANUAL\ELEC03
Gas Operated (Rotary)	MANUAL\GAS01
Gas Operated (Linear)	MANUAL\GAS02

Contents

Parts List.....	4
Arrangement Drawing.....	5
System Design.....	6
General Description	6
Operation.....	6
Maintenance	7

Parts List

Item No.	Description	No. Off
1	Case	1
2	Front Cover	1
3	Sleeve	1
4	Piston	1
5	Element Plate	1
6	Spring Plate	1
7	Spindle	1
8	Circlip	1
9	Element Spring	1
10	'O' Ring	1
11	'O' Ring	1
12	Seal	1
13	Locking Pin	1
14	Element	1
15	Spacer	1
16	'E' Ring	1
17	Set Screw	1
18	Element Plunger	1
19	Lock Nut	1
20	Label 'COOLER'	1
21	Label 'BYPASS'	1
22	Hammer Drive Screw	4
23	Washer	4
24	Seal	3

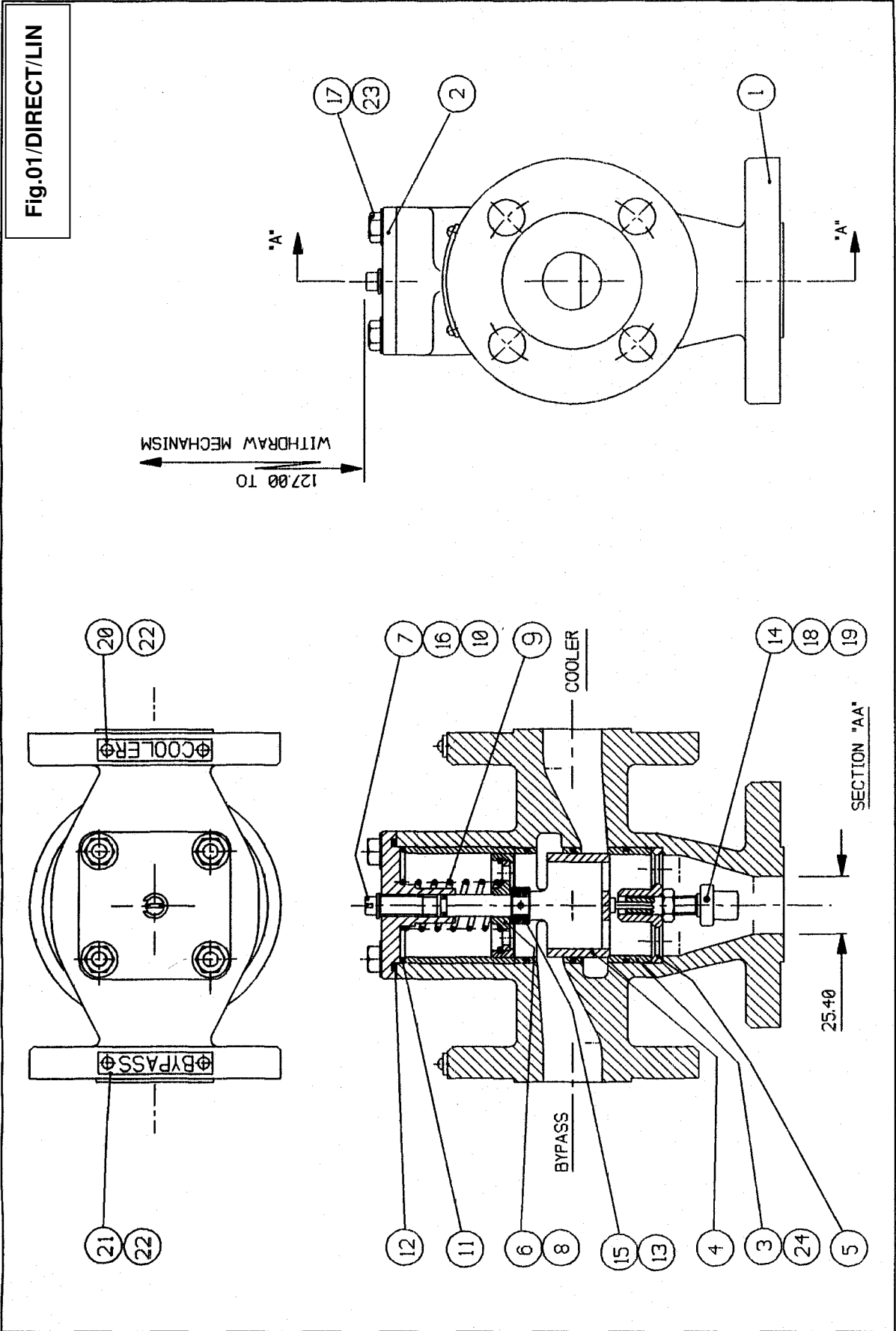

System Design

The system should be designed so that sufficient cooling is obtainable with less than full flow to the cooler and the valve will maintain a steady control temperature with partial flow through both cooler and by-pass. This control temperature will be approximately mid-way in the element range.

General Description

This design is of the 3-way type and may be used for either mixing or diverting applications.

The valve is operated by a wax-filled temperature sensitive element. Manual control at the valve is fitted as standard on this valve

Fig. 01/DIRECT/LIN shows a sectional arrangement of the valve. The three-ported flanged body (1) has the inlet/outlet port at the bottom with cooler and by-pass ports arranged in a 'T' configuration.

The drawing above shows the valve in the 'cold' position. Assuming the valve is installed as a mixer, fluid entering the by-pass port passes into the upper slots of the piston, down through the base of the piston and the element plate, and returns to the system via the lower port.

Operation

The temperature sensitive element (14) is carried in a plate (5) which has holes to allow flow past the element. Ports in the liner (3) coincide with angular recesses in the body leading into the cooler and by-pass ports. A piston (4) with holes in the base and slots at the upper ends controls the flow through the ports.

When the temperature of the fluid reaches the lower limit of the element operating range, the element spindle extends. This allows the fluid to pass into the cooler port and through the cooler to mix with the fluid flowing through

the by-pass, resulting in a cooling effect on the fluid in the system.

As the temperature increases, the piston is lifted progressively higher. At the upper limit of the temperature range, the by-pass ports in the sleeve are closed by the rising piston and all the fluid is routed through the cooler, giving maximum cooling effect.

On reduction of the temperature, the spindle of the wax element retracts and the spring (9) returns the piston until flow through the cooler is reduced sufficiently to stabilise the system temperature.

A spindle (7) is fitted through a plate (6) and secured by a circlip (8) in the top of the piston, and extends through the top cover of the valve, being sealed by an 'O' ring (10).

The valve incorporates a mechanism which enables the automatic mode to be overridden and the temperature controlled manually. The ability to control at a temperature lower than that being automatically maintained is of particular value when an individual section of the system is running 'hot' or in the unlikely event of element failure. Manual control is achieved by turning the spindle (7) anti-clockwise to screw up and raise the valve piston (4). Full flow to cooler will be obtained when the spindle has been raised approximately 8mm as indicated by the distance between top cover face and 'E' ring (16).

To return to automatic operation, turn the spindle (7) clockwise until the 'E' ring has been lowered back down on to the cover (2).

Maintenance

The following instructions assume that the valve is being used in a cooling water circuit but the remarks apply equally for valves installed in lubricating oil circuits.

Inspection Periods

We recommend that the valve be inspected internally after the initial test run to check for foreign matter that might have been in the system prior to start-up. See procedure for **dismantling of the valve**. Check seals for damage. If in doubt change the seals.

After this the valve should be inspected at intervals of approximately 8,000 running hours in closed systems. The element should be checked for signs of deterioration. **Change seals.**

If no problems have been encountered during operation then the element may be left but checked again at 16,000 running hours. If no problems, leave until next inspection and then consider replacement but in many cases it may not be necessary even at this stage. End user policy and operator experience will often dictate frequency of replacement.

Procedure for Dismantling

Ensure that the circuit is drained to below the valve level or that the valve is isolated from the circuit. Then, proceed as follows:

1. Remove the front cover nuts.
2. The front cover complete with all internals can then be withdrawn and the necessary cleaning carried out.
3. Further dismantling of the valve should not be necessary.

Procedure for Replacing Element

1. Remove the internals as described above.
2. Unscrew the locknut and element.
3. Screw the replacement element, plunger and locknut assembly into the element plate until the piston starts to lift. Unscrew the element $\frac{1}{2}$ a turn and tighten the locknut.

4. Refit the internals, and replace front cover nuts.

Procedure for Adjusting Operating Temperature

A limited amount of adjustment to the valve's operating temperature is possible as described and shown in Fig.02/DIRECT/LIN below.

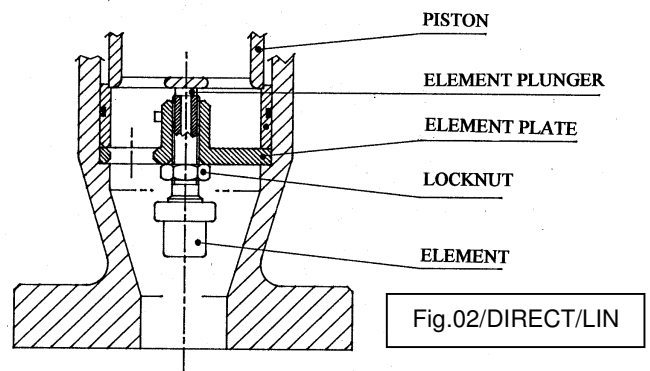

To increase the temperature at which the cooler port opens:

1. Remove the internals as described above.
2. Release the locknut and unscrew the element anticlockwise $\frac{1}{2}$ a turn per $^{\circ}\text{C}$ required adjustment. Retighten the locknut.
3. Refit the internals, and replace front cover nuts.

To decrease the temperature at which the cooler port opens:

1. Remove the internals as described above.
2. Release the locknut and screw the element clockwise $\frac{1}{2}$ a turn per $^{\circ}\text{C}$ required adjustment. Retighten the locknut.
3. Refit the internals, and replace front cover nuts.

Each time the valve is opened, it is recommended that the cover seal be replaced.

The temperature sensitive element is not a serviceable item, and in no circumstances should any attempt be made to dismantle it.